



Biomet® OrthoPak® Non-invasive Bone Growth Stimulator System



EBI BONE GROWTH STIMULATION

Description of the Biomet® OrthoPak® Non-invasive Bone Growth Stimulator System

The Biomet® OrthoPak® Bone Growth Stimulator is a nonsurgical treatment technique designed to promote the healing of bone fractures that have failed to mend in the normal period of time. This condition is commonly called a nonunion.

The condition of a nonunion is not rare. Approximately 1 in 20 bone fractures become a nonunion. The most common method of treating a nonunion has been bone graft surgery. In this procedure, bone is taken from another location of the patient's body and surgically implanted at the nonunion site. Metal rods or plates and bone screws also may be attached to the broken bone to secure the ends in place while it mends.

An alternative nonsurgical procedure was developed for the treatment of nonunions. This method incorporated the transmission of an electrical signal through the nonunion site to stimulate the healing process.

The OrthoPak has been designed so that it is convenient to use, comfortable to wear and safe to operate. Although this is an electrical stimulation treatment device, you will not feel any sensation of stimulation.



Your OrthoPak Consists of:

- Controller
- Electrodes
- A device holster
- Adhesive electrode cover patches to enhance electrode security (if needed)
- Two electrode lead wires to connect the electrodes to the controller
- Two rechargeable battery packs
- Battery charger and cradle
- An extremity band
- Foam Inserts for casted applications

Wearing the OrthoPak:

- The OrthoPak has been designed so that it is convenient to use, comfortable to wear, and safe to operate. You should begin using the OrthoPak device immediately after you have read the directions for use.

Directions for Use:

It is important that you familiarize yourself with the directions for use and the routine maintenance procedure for the OrthoPak. Please read the following directions carefully and make sure that you understand them thoroughly. Contact your local sales representative if you need additional clarification or help. Your full compliance with these directions will contribute greatly to the successful outcome of your treatment.

System Components

Electrodes

Electrodes are provided for patient use. Low profile Electrodes (Figure 1) are to be used in all applications of the OrthoPak. Electrodes are mounted on a release liner and are effective for multi day use. (See page 14.) A supply of electrodes is included with every assembly. The patient should replace electrodes every 1 to 7 days. Patients can order additional electrodes by calling 1-800-526-2579 and then dialing extension 6000.

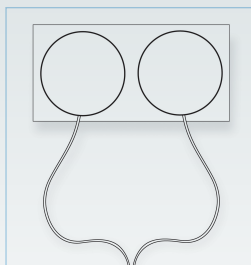

Figure 1

Electrode Cover Patches

Cover patches are to be used for non-casted applications by patients who are experiencing difficulty keeping the electrode pads in good contact with the skin.

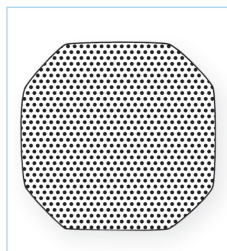

Figure 2

When the electrode retainer is properly applied over the electrode pad, you will be able to shower without removing the electrode pad. (Figure 2)

Device Holster

The device holster is designed to securely hold the OrthoPak in place. It has a clip on the back which allows you to wear the device on your waistband or belt.

Lead Wires

Two different length lead wires are included with the OrthoPak. You should choose the lead wire that best accommodates your needs for where you would like to wear the controller.

Additional lengths are available from Customer Service.

Operating Instructions

Each OrthoPak includes two battery packs. Always have one battery attached to the OrthoPak and have one battery charging in the battery charger. Both battery packs provided with the OrthoPak are partially charged prior to being packaged. Upon receipt of the OrthoPak device, it is recommended that you take the second battery pack, place it into the charger, and charge fully. In the meantime, you may use the first battery pack to begin your treatment immediately.

NOTE: The first battery pack may not provide a 24-hour treatment initially. Additional batteries are available through Customer Service. Each day, preferably at the same time, you should change the battery following these instructions.

Step 1

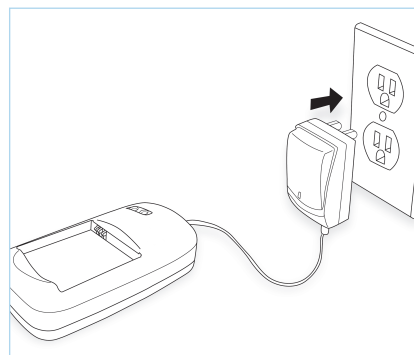

1. Plug the A/C adapter of the battery charger unit into a grounded wall outlet. Connect the A/C adapter to the charger cradle.

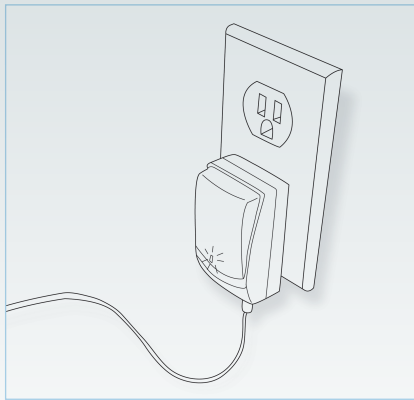

2. A green light on the A/C adapter will illuminate indicating that the A/C adapter is ready and connected to household power.

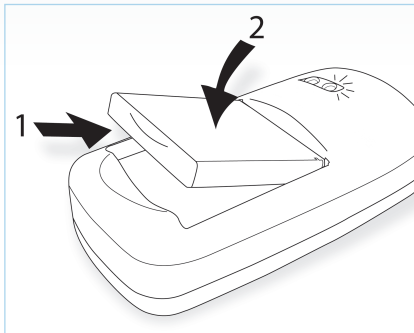

3. Following arrows, place the battery pack into the battery charger cradle as illustrated (1). Lightly press down on battery pack to ensure contact (2). The solid orange light on the charger cradle will illuminate indicating a proper connection and charging status.

NOTE: Make sure the battery in the charger is the one supplied with your stimulator.

⚠ Warning: Do not attempt to charge any other battery. Do not use the battery packs supplied with this unit in any other device. Use of the OrthoPak battery packs in any other device may cause damage or malfunction to the batteries and/or devices. Do not short circuit, overcharge, crush, mutilate, nail penetrate, heat, reverse the + or - terminals or disassemble the battery pack. Do not allow metal objects to come into contact with the battery pack terminals. These and any other

abuses of the battery pack may cause serious injury and/or burns. To ensure proper charging and safety, use only the charger supplied with your device. Keep battery pack dry. This battery pack must be disposed of properly. Disposal information can be obtained by contacting the Rechargeable Battery Recycling Corporation (RBRC) at 1-800-822-8837 in the US.

Battery Charging

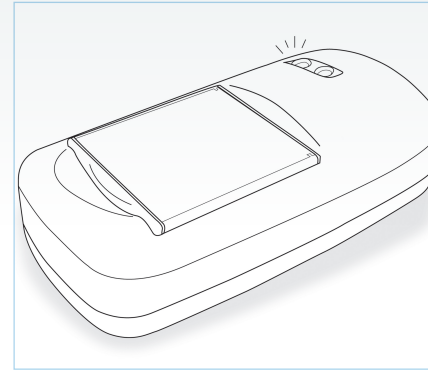

4. When the battery pack is fully charged the orange light on the battery charger cradle will be off. The green light should stay on. Otherwise check if the A/C adapter is appropriately plugged into the A/C outlet.

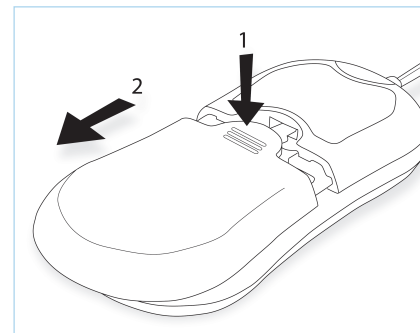

5. Remove the current battery pack from the OrthoPak and place that battery pack in the charger cradle for charging. Open the battery compartment by pressing the battery cover release button (1) and sliding the battery cover to open (2).

Step 2

Preparing the System to Begin Treatment

Gently press electrodes onto the skin. Depending on your ability to move after your surgery, it may be helpful to ask another person to help you place these electrodes on your skin. See page 14 for electrode instructions. Consult your local sales representative should you have questions about your electrode placement. Make sure you apply the electrodes after your skin has been cleaned and dried. If your skin becomes abnormally red at the electrode sites, the electrodes should be moved adjacent to the original sites. If redness does not go away after 48 hours with the electrodes moved, you should contact your prescribing physician.

Place the stimulator controller in a comfortable and convenient location for you to wear for your prescribed treatment period. If you decide to place the stimulator controller in the holster, place the holster in a comfortable and convenient location that is close to your fracture site.

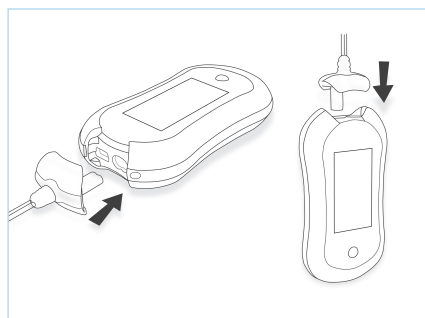

1. Connect the two electrode wires into the electrode lead wire. Insert the electrode lead wire plug into the jack at the top of the stimulator controller (Figure 1). Choose the electrode lead wire that reaches from the location of the device or device holster to your fracture site (where your electrodes should be placed). The device holster can be worn on a belt, attached to your waistband, or clipped onto the extremity band.

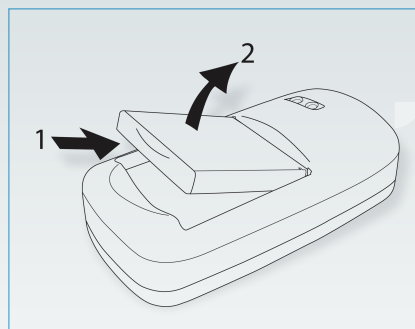

2. Remove the fully charged battery pack from the battery charger cradle by a gentle lift (2) of the small tab (1). The battery is now ready for connection to the OrthoPak.

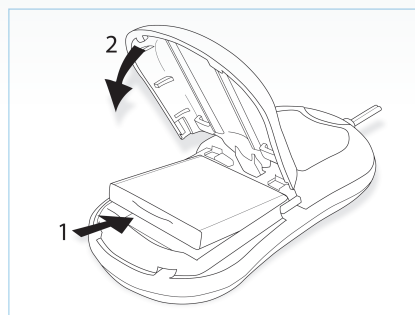

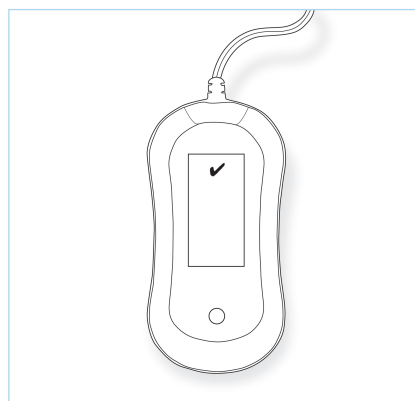

3. Insert the battery pack into the OrthoPak by placing it into the battery compartment (1) (replace the cover by sliding back to its closing position). The cover will snap into place (2).



4. When the electrodes are applied and are making good contact with the skin, there will be a blinking indicator "✓" icon (Figure 4).

If the audible alarm and the orange light flashes with the indicator  icon blinking, the battery charge is low. Install a fully charged battery pack.

If the audible alarm is beeping, the orange light is blinking, and the  icon is displayed, the continuity of the circuit has been interrupted. First, check that the electrodes are making good contact with the skin. If alarm is still on, detach the electrode and repeat this procedure with one of the other electrode lead wires supplied with your stimulator. If the alarm stops, the original lead wires may be defective. If the  icon appears, there is a problem with the stimulator. DO NOT ATTEMPT TO FIX IT YOURSELF. Contact Customer Service.

Helpful Hints

Loose Electrodes - Make sure that both electrodes are in complete contact with your skin. Moisten or replace worn electrodes if necessary.

Incomplete Circuit - Check all connection points, insuring tight fit of lead wire plug into the OrthoPak device and full engagement of electrode cable pin into electrode wire receptacle.

Broken Electrode Lead Wire - If you have checked the electrodes and the connections and the alarm continues, remove the old electrode lead wire. Attach a new electrode lead wire into the jack. An extra electrode lead wire is provided in the assembly. If the alarms still continue, please contact Customer Service.

Step 3

Recharging the Batteries -At room temperature, (24°C [75°F]), charging may take two to three hours. In warm or cold temperatures, the battery pack may take longer to charge. Follow Step 1 instructions.

Once Daily, Patients Should do the Following:

- Slide down the battery door (1, 2) on the back of the stimulator and remove the depleted battery pack.
- Remove the fully charged battery pack from the battery charger cradle (see preparing the System to Begin Treatment) and place the fully charged battery pack into the controller.
- Place the depleted battery pack into the battery charger for charging.

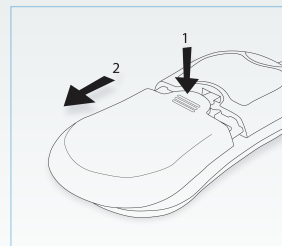





NOTE: The battery pack cannot be overcharged. If the battery pack is in the battery charger cradle and the battery pack is already fully charged, the charger will terminate the recharging process early. This will be indicated by the charger having no orange light when charging is complete. Do not be concerned if the battery pack is kept in the charger cradle for a long period of time.

When the OrthoPak Needs a Freshly Charged Battery Pack, the Following will Occur:

- The OrthoPak display will indicate the symbol for low battery charge. (P. 10) With the audio alarm engaged, beeping will occur.
- Only after inserting a charged battery pack into the OrthoPak will the message read . (P. 10)

LCD Symbol Descriptions and Instructions

The alarm defaults to audible alarm. Press the button below the display on the front of the stimulator, to silence the alarm. The light will continue to flash and the display will indicate the alarm condition.

| Symbol | Condition | Instructions |
|---|--|---|
| ✓ | Treating | Continue use |
|  | Audible alarm engaged | If beeping, depress the button engaged briefly to silence the alarm. Depress the button approximately 3 seconds to engage or disengage the audible alarm |
|  | Low battery charge | Insert a charged battery pack |
|  | Disconnection of lead wire | Confirm that each electrode is properly applied on the skin. See the electrode pouch for instructions. Confirm that the lead wire is attached properly. Replace the lead wire if necessary. |
| ⊗ | System error | Error in the stimulator – Contact Customer Service for assistance. |
|  | Device is connected to a PC | Device will not treat until USB cable is disconnected |
|  | End of operation/ Treatment Completion | Contact Customer Service |

Troubleshooting-Electrodes

- Change your electrodes as required. Different skin types will provide for a longer or shorter life of the electrodes. If the alarm indicates a disconnection, it is likely that either the lead wire connection is incomplete or the adhesive (gel) on the electrode is no longer working and the electrodes need changing. Check all lead wire connection points, to make sure that the electrode lead wire is tightly plugged into the top of the OrthoPak (See figure below) and that the lead wire connectors are completely inserted into both electrode connectors. If all the

connections are made and the symbol indicates a disconnection, it is probably time to change the electrodes.

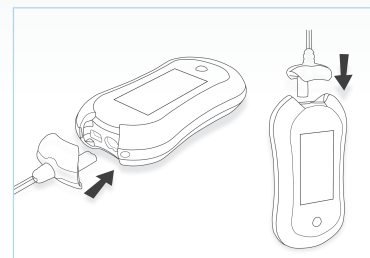

- Remove the old electrodes from your skin
- Wash your skin gently with soap and water then dry
- Remove new electrodes from the packaging and store the plastic liner for future use
- Gently press the electrodes on your skin in the same place as before. Ask another person for help if you cannot reach the site easily. If your skin is very red, place the electrodes slightly above or below the original sites. Call your prescribing physician if the redness does not go away in 48 hours. It is normal to note a slight pinkness of the skin after removal of the previous pair of electrodes. This pinkness will fade within a short period of time.

NOTE: The OrthoPak accurately records the number of days you receive treatment. This helps your doctor track your treatment.

Helpful Tips

- Keep the audible alarm setting in the “ON” position as much as possible. This alarm will help warn you of any problems with the device. During special occasions when you would like the device not to tell you audibly about stimulator problems, you may press the button for 3 seconds to turn off the audible alarm. It is recommended that you turn the audible alarm back “ON” as soon as possible by pressing the button for 3 seconds again.
- During an alarm condition, depressing the button quickly (0.5 seconds) will temporarily disable the audible alarm.
- Remove your OrthoPak when you bathe, shower or swim. You should also either remove the electrodes or cover them with the additional adhesive cover patches provided, as shown in Figure 8 if you prefer to leave the electrodes attached to the skin during bathing.
- Use the OrthoPak up to 24 hours per day. Your doctor will tell you when to stop using it. After 270 continuous treatment days of the OrthoPak will automatically turn off.

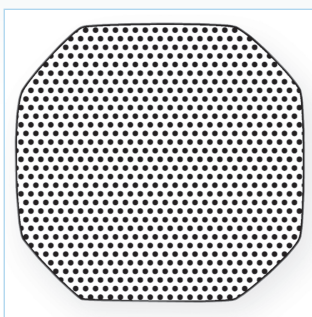

Figure 8

Caring for Your OrthoPak

- Do not use cleaning products or detergents on any part of the OrthoPak. Please use a damp cloth.
- Do handle the OrthoPak carefully. Dropping or rough handling can cause damage.
- Store the OrthoPak in a cool and dry place when you are not wearing it
- Contact Customer Service if you believe that the device has been damaged or is operating improperly

If You Have Questions

If you have questions about your OrthoPak or about any components within the assembly, contact Customer Service at 1-800-526-2579.

IMPORTANT: Any and all medical questions must be directed to your doctor.

Ordering Information

To order supplies, simply contact Customer Service directly. The following information is necessary to expedite any requests:

- Patient name
- Physician name
- Address to send replacement items (patient home, MD office, etc.)

CAUTION: Federal Law (U.S.A.) restricts this device to sale by or on the order of a physician.

 Single Patient Use/Prescription Only

Disposal Instructions

When treatment has concluded as determined by the prescribing physician, ZimVie requests that the patient disposes the OrthoPak according to local statutes and regulations.

Indications for Use

The OrthoPak is indicated for the treatment of an established nonunion acquired secondary to trauma, excluding vertebrae and all flat bones, where the width of the nonunion defect is less than one-half the width of the bone to be treated. A nonunion is considered to be established when the fracture site shows no visible progressive signs of healing. The original approval was based on a PMA Study, which included 69 patients with efficacy of 72.5%. An additional cohort of 21 recalcitrant patients with multiple prior procedures and unsuccessful electrical stimulation with different modality was added and yielded efficacy of 33.3%. Seventy-nine patients out of 90 treated had at least 4 years follow-up after the date of treatment termination for a follow-up rate of 88%. The follow-up results were 45 patients healed; four previously healed patients have died; three patients, who were "healing" at the end of treatment, were healed with additional treatment. Counting only the 45 unconditionally healed patients, the efficacy at 4 year follow-up was 50%. A subsequent survey of 295 patients conducted from March 1988 to September 1990 by an independent agency, yielded an efficacy of 73.2%.

Device Design Rationale

The OrthoPak provides a noninvasive, transdermally applied electrical treatment of nonunions acquired secondary to trauma. The transdermal application of the treatment current to the patient has been also referred to as "capacitive coupling", to denote the resulting capacitive phase shift between the treatment current and the applied voltage in the OrthoPak. The time varying electrical field developed in the tissue between the electrodes is distributed through a wide volume of tissues, including bone. Thus, some latitude is permitted in the placement of the electrodes. A 20 degree misalignment is allowed in the placement of the electrodes on either side of the nonunion site, and the permissible tolerance in the plane of the long axis of the bone is equal to the diameter of an electrode (i.e., plus or minus 1-3/8 inches). Utilization of this device allows full weight bearing on the casted extremity unless gross motion (greater than 5 degrees in any plane) at the nonunion site is presented. In such cases, weight bearing is not advised.

Contraindications

The use of this device is contraindicated if the individual has synovial pseudoarthrosis.

Warnings

Utilization of this device allows full weight bearing on the casted extremity unless gross motion (greater than 5 degrees in any plane) at the nonunion site is present. In such case, weight bearing is not advised and should not be permitted as this may compromise the effectiveness of the treatment. The safety and effectiveness of the use of the device on individuals lacking skeletal maturity has not been established. In the presence of a malignant nonunion, careful consideration on the use of this device must be undertaken on an individual basis, as treatment with this device is not yet intended to alter or affect the degree of malalignment.

Animal safety studies conducted to date indicate that the OrthoPak does not interfere with the normal intrinsic activity of the heart. However, the Stimulator does interfere with the operation of certain pacemakers. The concomitant use of the device and a pacemaker must be assessed on an individual basis, prior to use (such as with an electrocardiogram). The amplitude of the treatment current must be between 5 and 10 milliamperes RMS.

Treatment with this device is not recommended on patients whose electrical impedance of the tissue between the electrodes will not allow the device to operate within the prescribed 5 to 10 milliamperes range. The safety and effectiveness of the use of this device on individuals with nonunion secondary to, or in conjunction with, a pathological condition has not been established.

Animal studies conducted to date do not suggest any long term adverse effects from use of this device. However, long term effects in humans are unknown. General tissue sensitivity at the skin/electrode site with unknown specific etiology may occur. This tissue sensitivity may be caused by the electrode gel, excess perspiration or a combination of both. Such a reaction generally resolves spontaneously following diagnosis and correction of the underlying cause.

Other components, accessories and parts may not be compatible, and may damage the device. If any component does not function properly, contact ZimVie. No attempt should be made to modify or repair the device.

Precautions

Although laboratory teratological studies performed with this device demonstrate no adverse findings, the safety of this device used during pregnancy and nursing in humans has not been established.

Compliance with the treatment schedule, daily battery pack change and proper maintenance of the device and the change of the electrodes are essential. The device will not perform properly and treatment may be unnecessarily prolonged if you fail to adhere to the care routine. Components in this system are to be used only with ZimVie approved parts. No attempt should be made to modify or repair this device.

Adverse Events

NOTE: With the exception of the following, no known adverse effects have resulted from the use of this device:

General tissue sensitivity at the skin/electrode site with unknown specific etiology may occur. This tissue sensitivity may be caused by the electrode gel, excess perspiration or a combination of both. Such a reaction generally resolves spontaneously following diagnosis and correction of the underlying cause.

Electrode Instructions for Use

Do not open outer packet until ready to use.

- 1) Tear open packet.
- 2) Remove electrode from clear plastic backing liner.
- 3) Wet finger with tap water and moisten entire gel area.
- 4) Place electrode on skin.
- 5) Connect electrode to electrode lead.

Renewal

- 1) With continuous use, electrodes may dry out.
- 2) To renew, wet finger with tap water and moisten entire gel area.
- 3) Reapply electrode to skin. Store in a cool place.

Options

The industry's most comprehensive options:

- PEMF, CC and DC
- Anatomy specific coils
- Wear-time choice

Evidence

- Backed by proven science
- Multiple scientific papers
- The proof is in the patient

Experience

Recognized as an industry pioneer with EBI lineage, ZimVie has helped over one million people.

For more information, visit ZimVie.com



ZimVie

1 Gatehall Drive,
Suite 303
Parsippany, NJ 07054
1-800-526-2579



Legal Manufacturer

Mfd. by: EBI Patient Care, Inc.
A ZimVie Company
484 Calle E
Guaynabo, PR 00969 USA

Unless otherwise indicated, all trademarks herein are the property of ZimVie Inc. and its subsidiaries, including EBI, LLC, Inc. (collectively, "ZimVie"). Unless otherwise indicated, all products herein are manufactured, marketed, and distributed by ZimVie. For additional product information, please refer to the individual product labeling or instructions for use. Federal Law (U.S.A.) restricts this device to sale by or on the order of a physician. Rx Only. Single Patient Use Only. Distribution to any other recipient is prohibited. This material may not be copied or reprinted without the express written consent of ZimVie.

PN# 1067800-00 Rev. G, ZV1298 REV B 02/24. ©2024 ZimVie Inc. All rights reserved.