

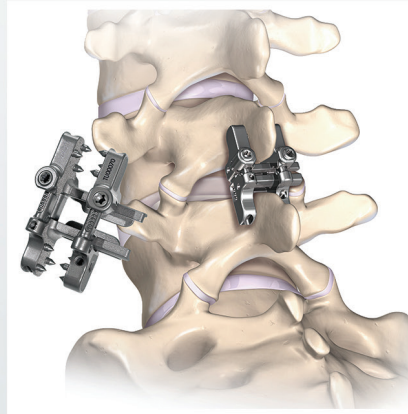

# Alpine XC™

## Adjustable Fusion System

### Surgical Technique Guide



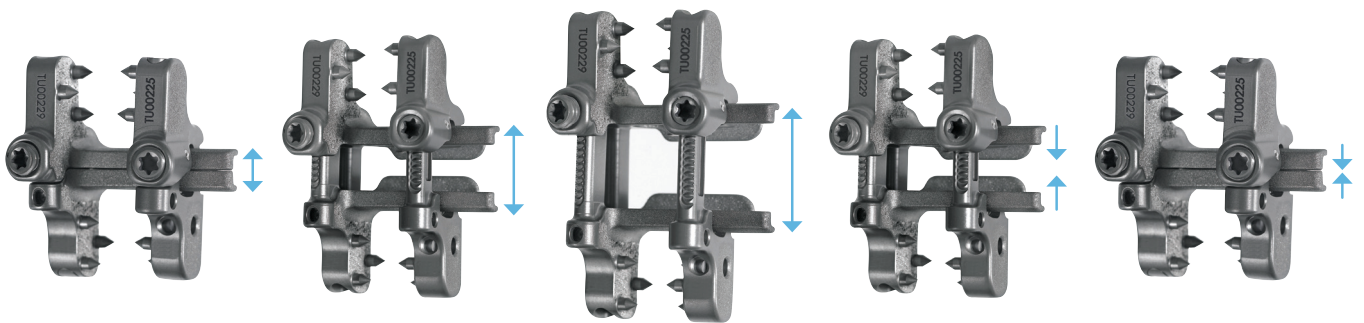
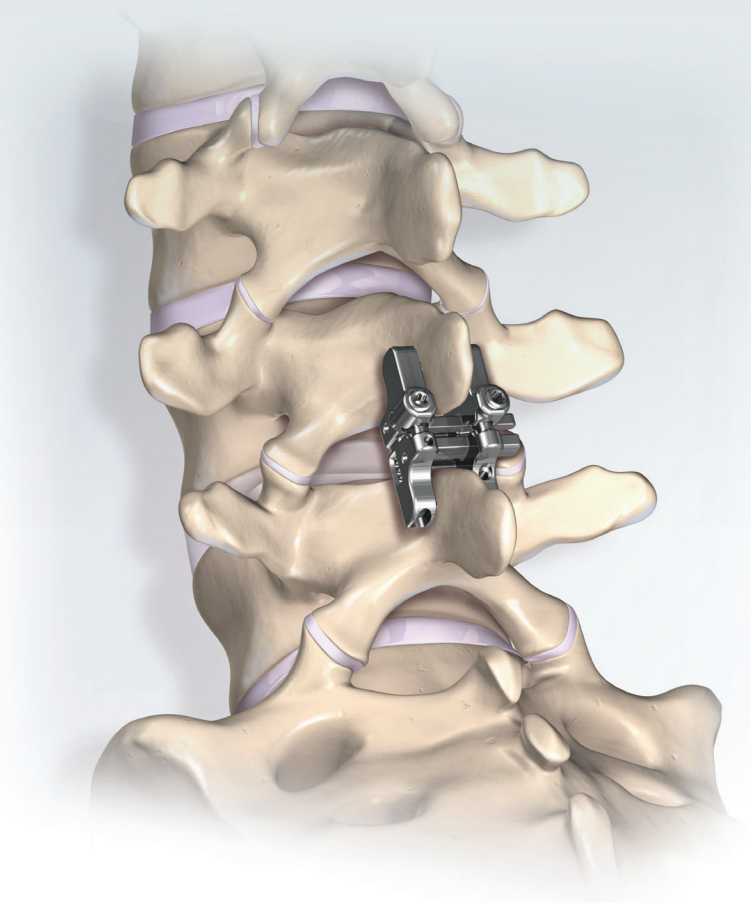

Designed to help optimize surgical results when using spinous process fixation to promote fusion.

## Table of Contents

|   |    |
|---|----|
| Device Description  | 4  |
| Patient Positioning and Surgical Access                         | 5  |
| Site Preparation  | 6  |
| Choosing an Implant Type  | 10 |
| Preparing an Implant for Insertion                              | 11 |
| Implant Insertion   | 16 |
| Implant Sizing  | 18 |
| Final Implant Adjustment  | 19 |
| Final Tightening  | 20 |
| Bone Grafting and Closure                                       | 22 |
| Removing the Implant  | 23 |
| Instruments   | 24 |
| Implants  | 25 |
| Important Information on the Alpine XC Adjustable Fusion System | 26 |

ZimVie does not practice medicine. This technique was developed in conjunction with a health care professional. This document is intended for surgeons and is not intended for laypersons. Each surgeon should exercise his or her own independent judgment in the diagnosis and treatment of an individual patient, and this information does not purport to replace the comprehensive training surgeons have received. As with all surgical procedures, the technique used in each case will depend on the surgeon's medical judgment as the best treatment for each patient. Results will vary based on health, weight, activity and other variables. Not all patients are candidates for this product and/or procedure. Caution: Federal (USA) law restricts this device to sale by or on the order of a surgeon. Rx Only.

# Device Description

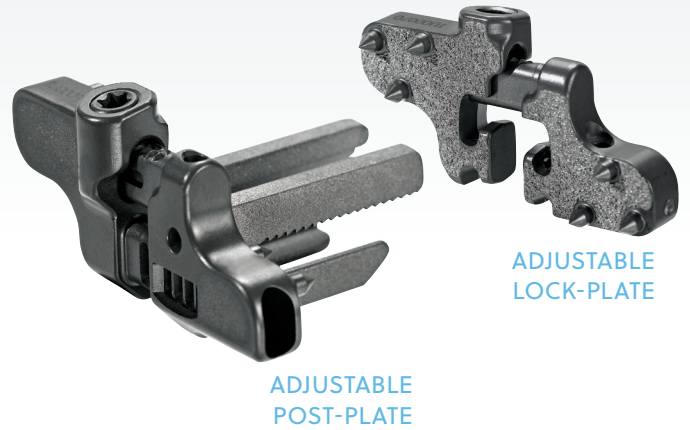
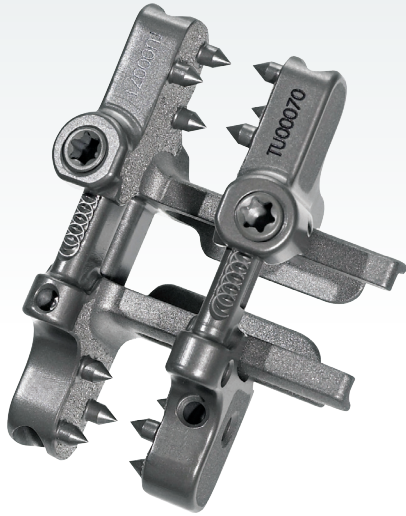

ADJUSTABLE  
LOCK-PLATE

ADJUSTABLE  
POST-PLATE

The **Alpine XC Adjustable Fusion System** provides robust posterior fixation in the thoracic and lumbosacral spine. It features an adjustable-length interspinous post, as well as adjustable-length fixation plates, which allow for expansion and compression.

## ADJUSTABLE Post-Plate

| Post Length | Adjustable Height Range | Part Number |
|-------------|-------------------------|-------------|
| Medium      | 6↔18mm*                 | 6305-1003   |
|             | 10↔18mm*                | 6305-1103   |
| Wide        | 6↔18mm*                 | 6306-1003   |
|             | 10↔18mm*                | 6306-1103   |

\* Special Order

## ADJUSTABLE LOCK-Plate

| Part Number |
|-------------|
| 6310-1003   |



# ■ Patient Positioning and Surgical Access

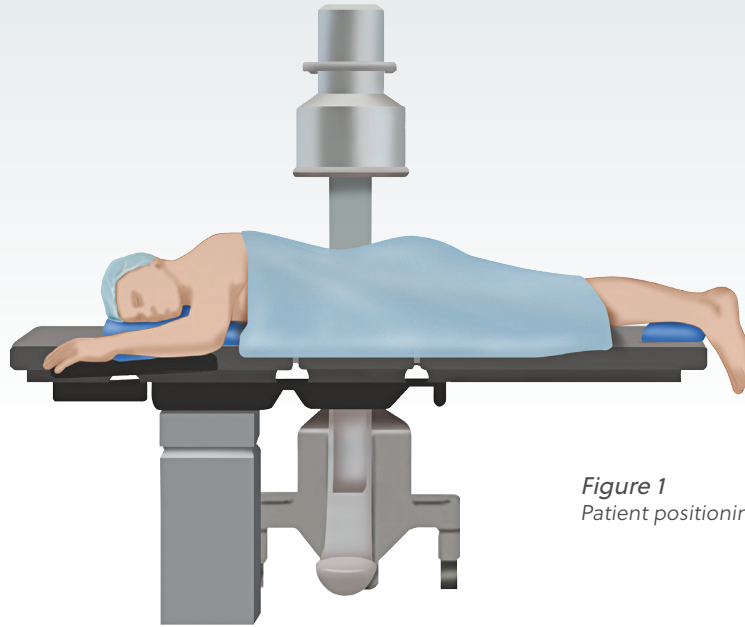

*Figure 1*  
Patient positioning

**Note:** Interbody fusion technique is not covered in this technique guide. If performing an interbody fusion, disc preparation and interbody spacer placement are performed prior to placement of the Alpine XC device.

## STEP 1

- Position the patient in the prone position on the operating table (**Figure 1**).

**Note:** The type of frame used depends on the intended procedure, but as a rule of thumb, select the same type of patient positioning that would be chosen if a pedicle screw/rod construct were to be used instead. Avoid hyperlordosing or kyphosing across the operative level.

## STEP 2

- Identify the spinous processes at the level to be instrumented using manual palpation and intraoperative imaging.
- Spinal needles may be inserted to properly estimate and limit the length of the incision.

## STEP 3

- Make a midline incision about 3–5cm in length to expose the spinous processes at the operative level.

## STEP 4

- Elevate the paraspinal musculature and other soft tissue to expose the spinous processes and lamina to the medial border of the facet joints.
- Obtain a second lateral fluoroscopic image with radiopaque markers (clamps) affixed to the spinous processes to confirm the proper level.

## Site Preparation

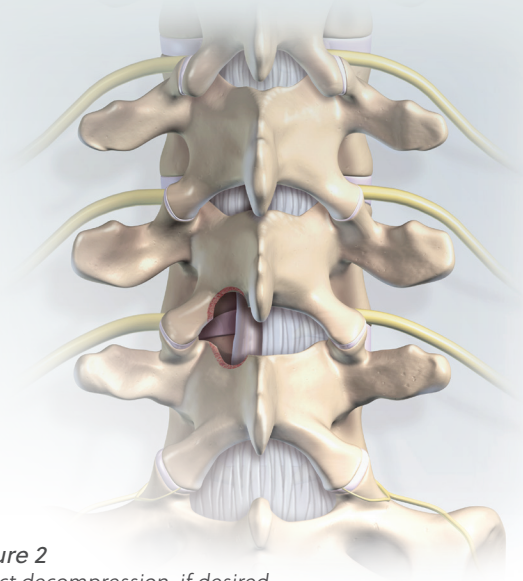

*Figure 2*  
Direct decompression, if desired

### STEP 5

- Clear the fusion site of soft tissues, and lightly decorticate the bone surfaces.
- A burr, rongeur and/or rasp may be used to prepare the interspinous space.
- Depending on the surgeon's preferred technique, the supraspinous ligament (SSL) and interspinous ligament (ISL) may be left intact, reflected or removed entirely.
- Possible reasons for leaving the ISL/SSL intact include:
  - Using the intact SSL as a natural inhibitor to prevent over-distraction and guide proper implant sizing.
  - Desire to preserve as much of the natural anatomy as possible.
- Possible reasons for removing the ISL/SSL include:
  - Increased visualization to facilitate a decompression.
  - Simplified device implantation.
  - Ability to pack bone graft material posterior to the device for a supplemental fusion mass.

### STEP 6

- If a direct decompression is desired, perform a conservative laminotomy, partial facetectomy, foraminotomy or other decompression procedure as needed (**Figure 2**).
- Caution:** Do not remove excessive amounts of bone, particularly from the spinous processes. Aggressive bone removal may increase the risk of intraoperative or postoperative fracture of the spinous processes.
- Decorticate the desired bone surfaces, preparing the fusion sites for bone graft. This may include the remaining lamina, facets and transverse processes (if they are exposed).

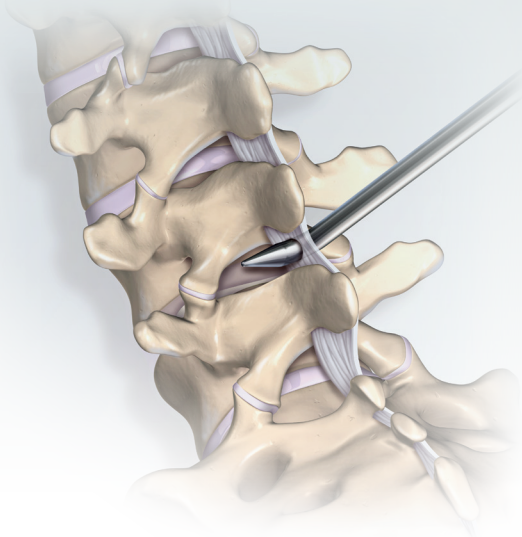

**Figure 3**  
Puncture interspinous ligament

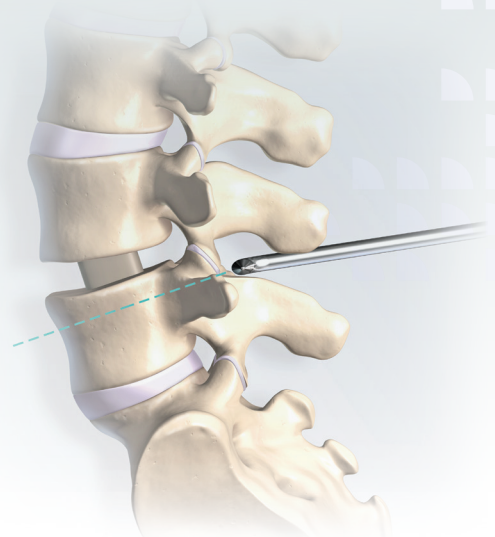

**Figure 4**  
Confirm level and position

### STEP 7

- If the facets are hypertrophied and do not allow for proper anterior seating of the implant, they may be trimmed.

**Tip:** If insertion of the dilator is difficult (i.e., “top-down” approach) after trimming the facet joints, consider removing the interspinous ligament/supraspinous ligament to facilitate easier insertion of the implant from posterior to anterior. Forcing the dilator from an awkward trajectory because of anatomical constraints may cause an inadvertent fracture of the spinous process.

### STEP 8

- If the interspinous ligament has been left intact, insert the **initial dilator** (attaches to the **quick connect handle** [gray]) and puncture the interspinous ligament, placing it as far anterior as possible (**Figure 3**).

**Note:** Anterior placement reduces stress on the spinous processes and allows fixation to the thicker, stronger base of the spinous process / lamina junction. Posterior placement may increase the risk of spinous process fracture.

### STEP 9

- With the initial dilator in place, confirm that the operative level is correct and placement is appropriate (i.e., anterior placement).
- **Note:** In the lumbar spine, the middle of the device should be roughly in line with the pedicle of the inferior operative level. For example, with an L4–L5 fusion, the device should be roughly in line with the pedicle of L5 (**Figure 4**).

## Site Preparation *(continued)*

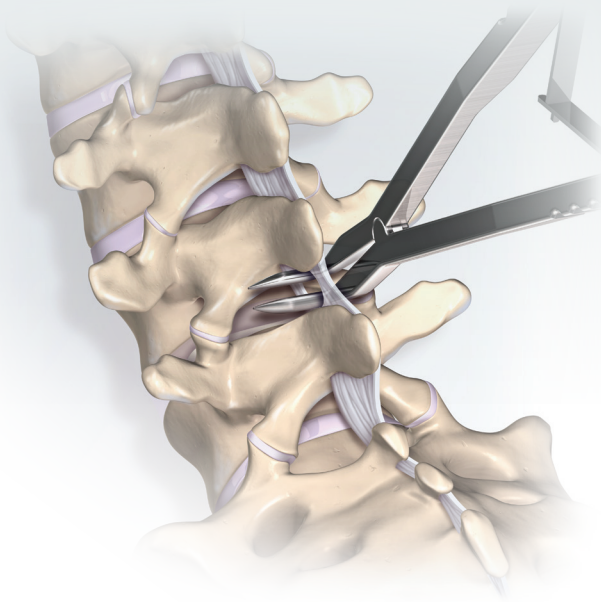

**Figure 5**  
Determine the size of the interspinous space

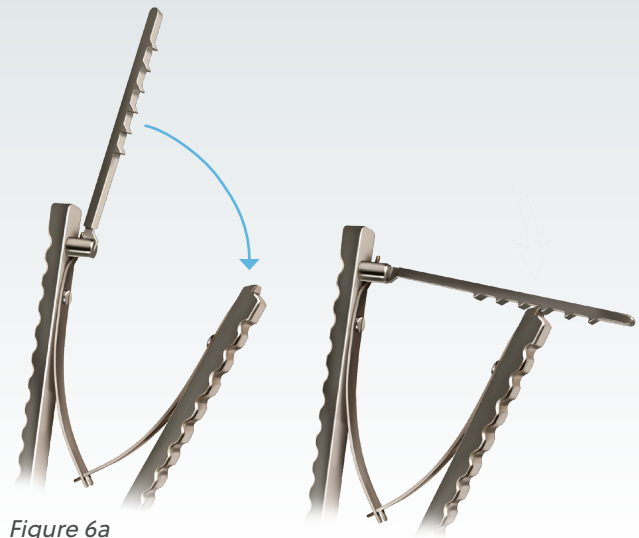

**Figure 6a**



**Figure 6b**

### STEP 10

- Using the **spreader**, measure the interspinous space and desired distraction. This measurement will be used to help guide implant sizing (**Figure 5**).

**Caution:** Do not over-distract the interspinous space. Excessive force may fracture or weaken the spinous processes.

- To ensure optimal tactile feedback during distraction, keep the spreader's ratchet up (disengaged) while dilating the space (**Figure 6a**).

Once the desired tension is achieved, drop the ratchet down and note the size measured (**Figure 6b**). This should serve as a guide for subsequent instrument (rasp) and implant sizing.

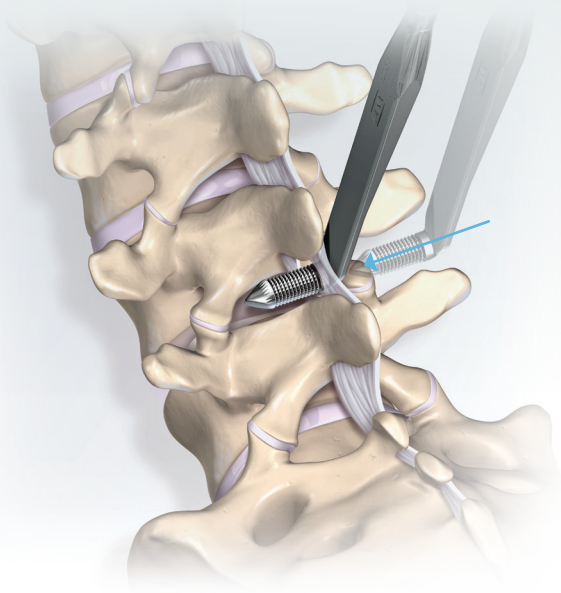

*Figure 7*  
Rasp

## STEP 11

- Attach the gray handle to the desired **rasp**.
- Insert the rasp into the interspinous space, and lightly decorticate the surfaces of the spinous processes to prepare the space for insertion of the interspinous post (**Figure 7**).
- If necessary, repeat the decortication process with a larger size rasp.
- Remove the rasp from the interspinous space.

## STEP 12

- If it is desired to pack bone graft in the facets or overlaid on the lamina, it may be easier to do this prior to implantation of the device, since the post overhang may obstruct access to these areas.
- Depending on the procedure being performed, it may be desired to release the facet joint to facilitate compression or distraction at the operative level.

# Choosing an Implant Type



## POST LENGTH

Two lengths of interspinous posts are available: Medium (21mm) and Wide (24mm).

A Medium is typically the first choice, since it minimizes the amount of extraneous post that overhangs and reduces the likelihood of interfering with the anatomy (i.e., a hypertrophic facet). However, if the spinous process is so thick that the lock-plate cannot engage the Medium post, a Wide post may be used.

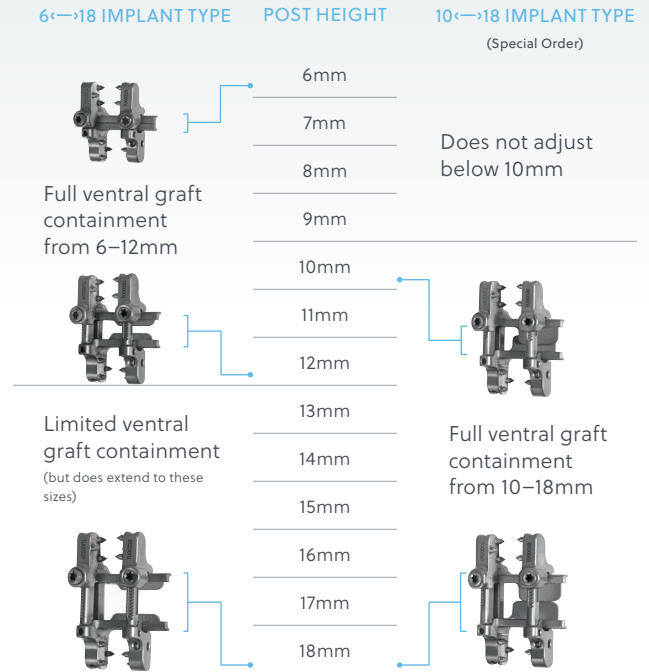

## ADJUSTMENT RANGE VS. GRAFT CONTAINMENT

The 6←→18 type implant has an interspinous post that ranges from 6–18mm in height. Graft is contained by ventral shields up to 12mm. Beyond 12mm, the 6←→18 implant type begins to lose its graft containment capability.

If a size greater than 12mm is expected and a surgeon desires more graft containment, the special order 10←→18 implant type may be used. It has a smaller adjustment range (10–18mm) but has wider shields to contain graft throughout that entire range.



# Preparing an Implant for Insertion



*Figure 8*  
Ensure set screws are backed up

## STEP 13

**Note:** To expedite the surgery, these steps may be performed by the surgical assistant at the beginning of the procedure, prior to the surgeon being ready for device implantation.

- To ensure smooth implant adjustment, locking set screws are preassembled to the post-plate and lock-plate and are preconfigured in a backed-up position using thread peens. A thread peen is a deformation of the thread form (**Figure 8**) that creates slight, initial resistance between the set screw and threaded hole to ensure the set screws maintain their position prior to final tightening.

# Preparing an Implant for Insertion *(continued)*

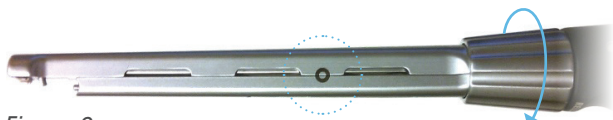

Figure 9  
Form an "O"

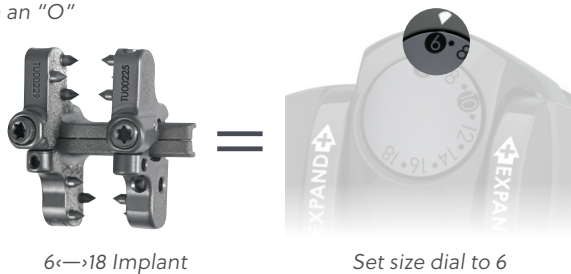

Figure 10a

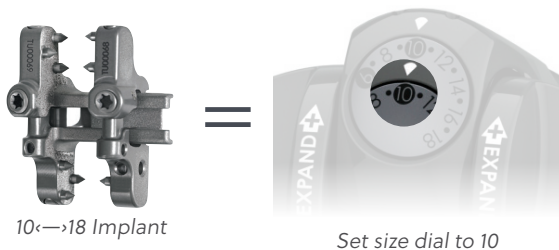

Figure 10b

## STEP 14

Prepare the **inserter/adjuster (Figure 9)** for attachment to the implant.

- Rotate the lock nut in the "RELEASE" direction until the laser marks on the side of the shaft form an "O" for Open (**Figure 9**).
- As instructed on the caddy, turn the adjustment knob so that the size dial is set to 6 (**Figure 10a**). If the Special Order 10←→18 implants are used, the size dial should be set to 10 (**Figure 10b**).
- This ensures that the size dial gives a more accurate reading of the corresponding size of the implant upon subsequent adjustment.



**Figure 11a**  
Insert the inserter/adjuster into a "Y" or "Z" pocket

**Figure 11b**  
Slide toward implant



**Figure 11c**  
Tighten the lock nut to form an "S"

## STEP 15

Attach the inserter/adjuster to a post-plate. Attachment is most easily done while the implants are still in the caddy.

- Insert the tip of the inserter/adjuster into a caddy pocket marked "Y" (for Medium posts) or "Z" (for Wide posts) (**Figure 11a**).
- Slide the inserter/adjuster toward the implant to engage the angled pin and adjustment gear with the lateral face of the post-plate (**Figure 11b**).

- Rotate the lock nut until the laser marks form an "S" (Secure), indicating the locking pin is fully seated in the implant (**Figure 11c**).
- Remove the implant from the caddy, and manually and visually confirm that it is secured to the instrument. Rotate the adjustment knob to confirm the ability to adjust the implant. Once confirmed, adjust the implant back to the fully collapsed configuration so that it is ready for implantation.

## Preparing an Implant for Insertion (continued)

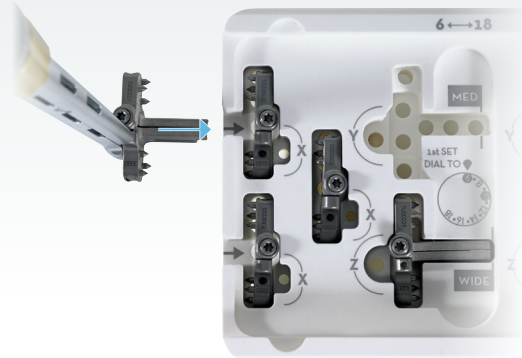

**Figure 12**  
Optional preassembly



**Figure 13a**  
Insert lock-plate inserter  
in "X" pocket

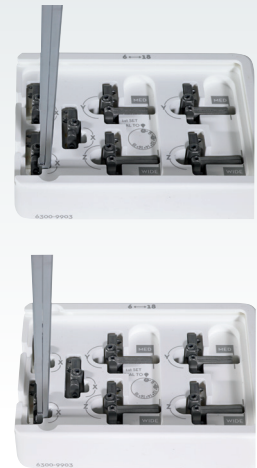

**Figure 13b**  
Slide toward implant

### STEP 16

- The implant construct (post-plate plus lock-plate) may be preassembled prior to implantation (if the supraspinous ligament is sacrificed) or assembled in situ.
- If preassembling the implant construct, it is recommended to have the two plates maximally separated to minimize spike interference with the spinous processes during insertion.
- The caddy is designed to easily allow the lock-plate to be preassembled on to the post-plate with maximum spike separation distance.
- To preassemble using the caddy, insert the post-plate (attached to the inserter/adjuster) into the channel marked with an arrow at the end of the caddy (**Figure 12**).
- Slide the post-plate into the channel, and into the lock-plate, until the post hits the wall of the caddy. The assembled plates can now be taken out of the caddy; the integrated ratchet in the implant will provisionally keep the lock-plate secured on the tip of the post.

### STEP 17

If it is desired to assemble the lock-plate to the post-plate in situ (e.g., if the ISL/SSL have been preserved), attach the **lock-plate inserter** to a lock-plate.

- Insert the tip of the lock-plate inserter into a caddy pocket marked "X" (**Figure 13a**).  
**Note:** There is only one type of lock-plate; it fits onto any of the post-plate options.
- Slide the lock-plate inserter toward the implant to insert the engagement pin into the corresponding hole in the lateral face of the implant (**Figure 13b**).

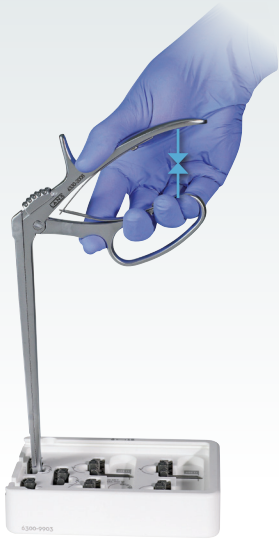

*Figure 13c*  
Squeeze handle



*Figure 13d*  
Engage thumb lock

- Squeeze the handle of the lock-plate inserter to extend the locking pin into the implant (**Figure 13c**).
- Slide the thumb lock of the lock-plate inserter up to retain the implant (**Figure 13d**).

**Note:** While the lock-plate inserter is attached to the implant, the provisional ratchet is disengaged, allowing for the lock-plate to freely slide on or off the post-plate. Once the lock-plate inserter is removed, the ratchet will provisionally hold the lock-plate to the post-plate.

## STEP 18

- Prior to inserting the implant in the patient, ensure that the implant is in the fully collapsed (smallest) configuration to facilitate insertion.

# Implant Insertion

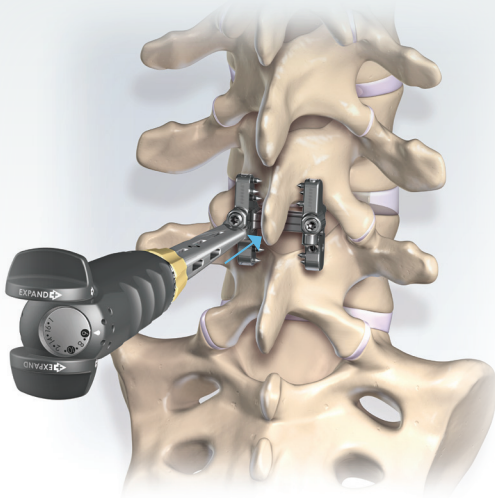

Figure 14  
Insert construct

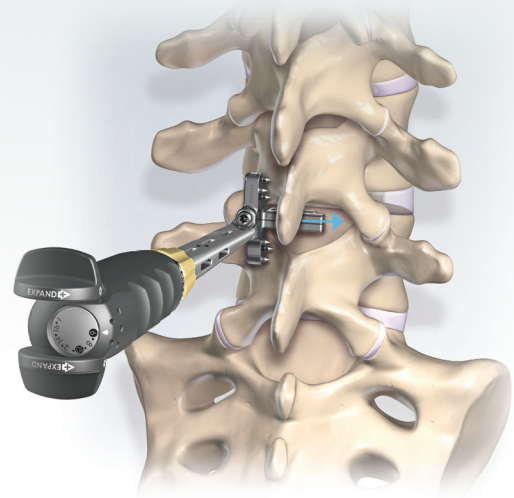

Figure 15a  
Insert post-plate

## STEP 19

The implant may be optionally inserted  
**(A)** preassembled or **(B)** assembled in situ.

**(A)** If the implant construct is preassembled (i.e., if the supraspinous and interspinous ligaments have been removed):

- The implant construct may be inserted with just the inserter/adjuster. The lock-plate will be provisionally held to the post-plate with the implant ratchet.
- Insert the construct from a direct-midline “top-down” approach, with the goal of placing the implant as far anterior and close to the lamina as possible (**Figure 14**).

**(B)** If the implant construct will be assembled in situ:

- Insert the post-plate through the interspinous space previously created by the initial dilator and/or rasp, with the goal of having the implant as anterior as possible (**Figure 15a**).

**Note:** Do not yet expand the post-plate; it must be in the collapsed configuration to allow the lock-plate to connect to it.





*Figure 15b*  
Attach lock-plate

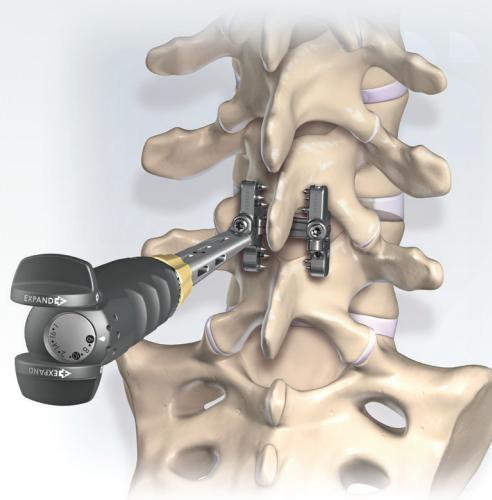

*Figure 15c*  
Remove lock-plate

- Using the lock-plate inserter, insert the lock-plate and partially slide it onto the post-plate (**Figure 15b**).

**Note:** To facilitate subsequent expansion, it is important to leave enough clearance between the spikes and the spinous process so that the plates can telescope unobstructed. This likely means that the post will be flush or slightly protruding from the lateral face of the lock-plate.

- With the lock-plate in the desired position, disengage the thumb lock on the lock-plate inserter and remove the lock-plate inserter from the implant (**Figure 15c**).

**Note:** With the lock-plate inserter removed, the implant ratchet is now engaged and can “click” along the post of the post-plate. If the lock-plate needs to be slid back laterally (or removed entirely), re-attach the lock-plate inserter to disengage the ratchet.

# Implant Sizing

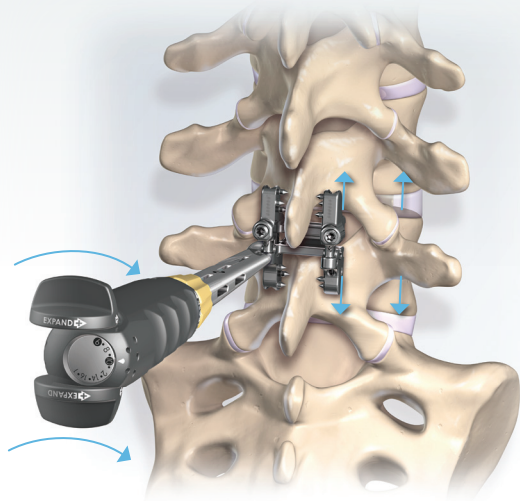

*Figure 16*  
Expand to “neutral” fit

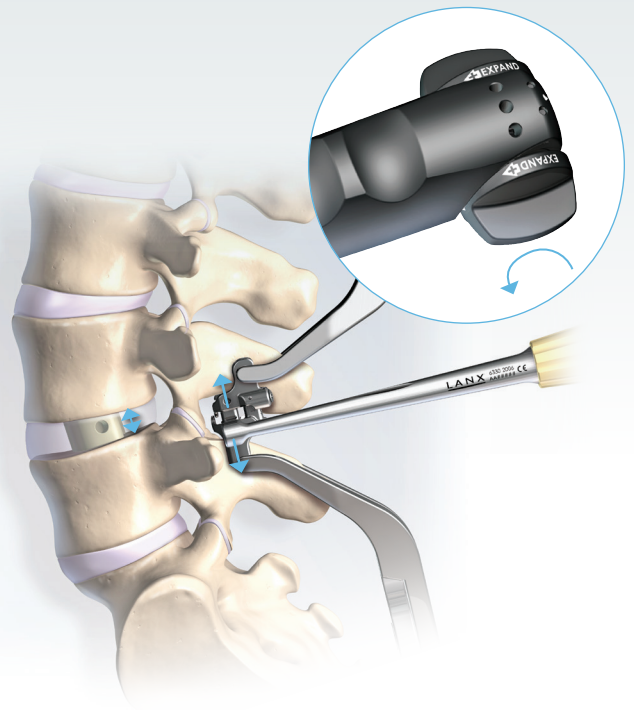

*Figure 17*  
Optional indirect  
decompression

## STEP 20

- Using the adjustment knob on the inserter/adjuster, expand the implant assembly until the interspinous post is in contact with the spinous processes above and below. This is the “neutral” fit, prior to any subsequent distraction or compression of the segment (**Figure 16**).
- This should approximately correspond to the interspinous space measurement previously noted with the spreader instrument.
- Watch for the spinous processes just beginning to spread open from their neutral state to visually confirm when the proper initial sizing is reached.

## STEP 21

- If indirect decompression is desired, the implant may be expanded beyond a “neutral” fit before seating the spikes (**Figure 17**).

## STEP 22

- Confirm appropriate implant placement with radiographic imaging. Adjust positioning as necessary.

# Final Implant Adjustment

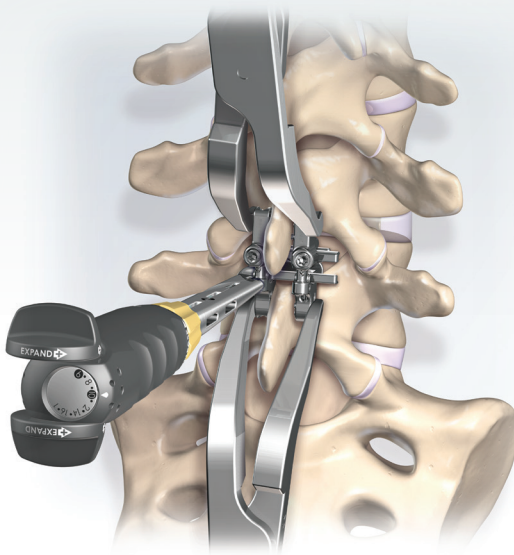

**Figure 18**  
Seat the spikes into the bone

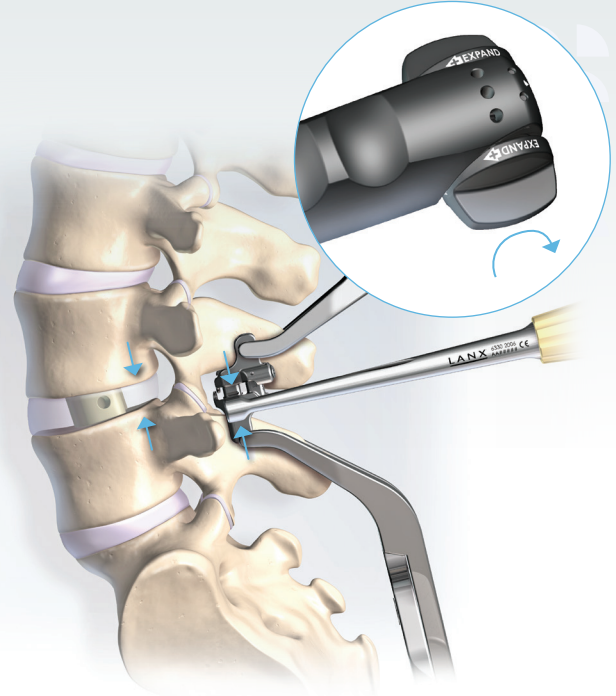

**Figure 19**  
Optional cage compression

## STEP 23

**Tip:** For added stability, it is recommended to leave the compressors on the implant while making any final size adjustments. The compressors will need to be held as a counter-torque during final set screw tightening, so keeping the compressors on the implant during size adjustments will save steps.

- Using the **compressors**, compress the spikes into the bone.
- Squeeze the cranial and caudal ends simultaneously or alternate clicks back and forth.
- Visually and manually confirm that the spikes are seated in the bone, with good apposition of the plates against the sides of the spinous processes (**Figure 18**).

**Note:** Take care not to over-compress the spikes and risk crushing or weakening the cortex, thereby increasing the risk of spinous process fracture (i.e., maximum compression force does not necessarily equate to better fixation).

## STEP 24

- If compression is desired (e.g., to compress on to an interbody cage), turn the adjustment knob in the negative direction (**Figure 19**).

**Note:** Take care not to over-distract or over-compress, which may cause excessive stress on the spinous processes. Due to the mechanical leverage of the inserter/adjuster instrument, it is recommended to use fluoroscopy, as well as tactile feedback, to determine the proper amount of distraction or compression.

## STEP 25

- Once final size adjustments have been made, confirm proper sizing and placement with fluoroscopy.

## Final Tightening

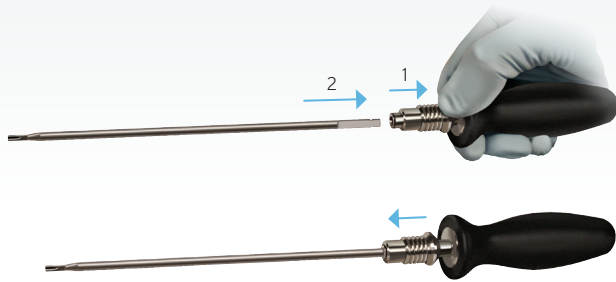

*Figure 20*  
Attach the driver to the handle

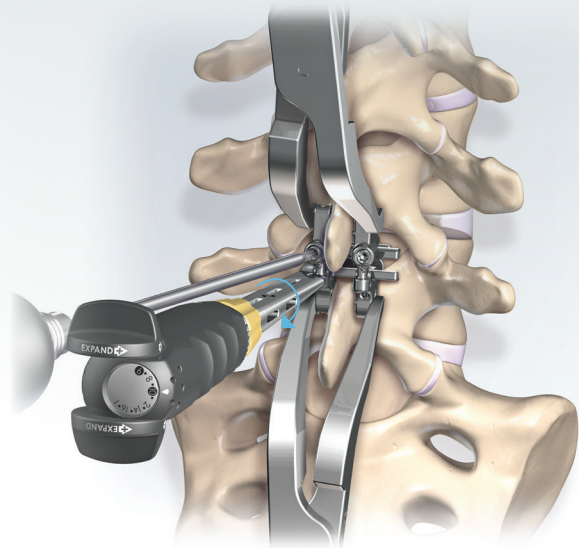

*Figure 21*  
Lock both set screws

### STEP 26

- Attach the **set screw driver shaft** to the **torque limiting handle** (black) (**Figure 20**).

### STEP 27

- While keeping the compressors on the plates to serve as a counter-torque, and keeping the inserter/adjuster attached to the post-plate to maintain the adjusted implant size, fully seat the set screw driver in a set screw (it does not matter which set screw is tightened down first).
- The set screws are angled out laterally 10° for ease of access.

### STEP 28

- Tighten both set screws until the torque handle clicks twice (**Figure 21**). As the set screws are tightened, initial light resistance will be felt as the set screws pass the thread peens.

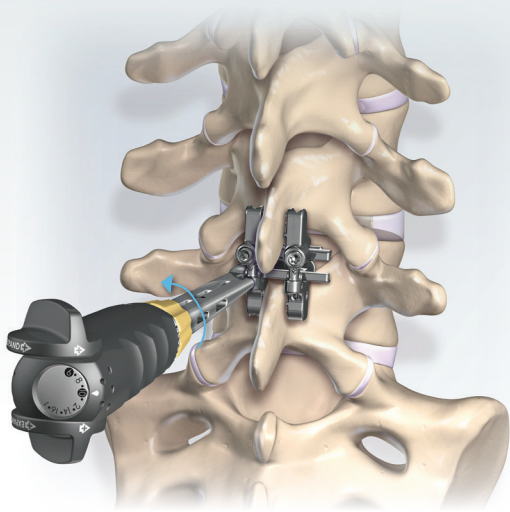

**Figure 22**  
Loosen the lock nut by hand. If needed, also loosen the adjustment knob to relieve any tension.

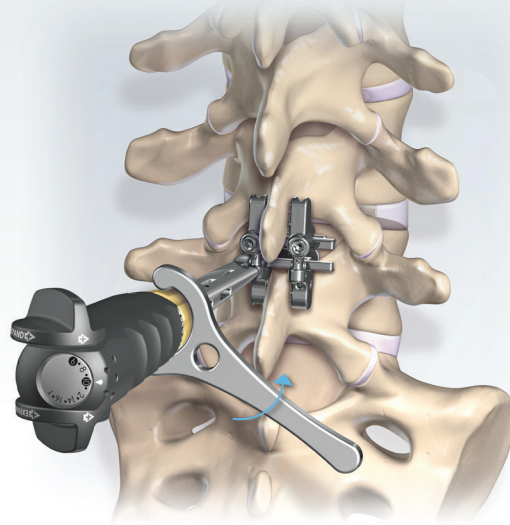

**Figure 23**  
As a last resort, use the removal wrench

### STEP 29

- Remove the set screw driver and compressors.

### STEP 30

- Remove the inserter/adjuster from the implant by loosening the lock nut (**Figure 22**).
- **Note:** If a significant compressive or distractive load was applied to the implant, there may be residual tension within the inserter/adjuster, which may make loosening the locking nut more difficult. To relieve this tension, turn the adjustment knob in the direction opposite to the applied load, approximately half of a turn, and then attempt to re-loosen the lock nut. If the lock nut continues to be too tight to loosen by hand, the **removal wrench** can be slid onto the lock nut for additional leverage (**Figure 23**).

### STEP 31

- Visually and manually confirm that the implant is rigidly fixated to the bone.
- Confirm that there is no encroachment of the device on the central canal.
- Obtain final A/P and lateral fluoroscopic images to confirm that the implant is in good position.



## Bone Grafting and Closure

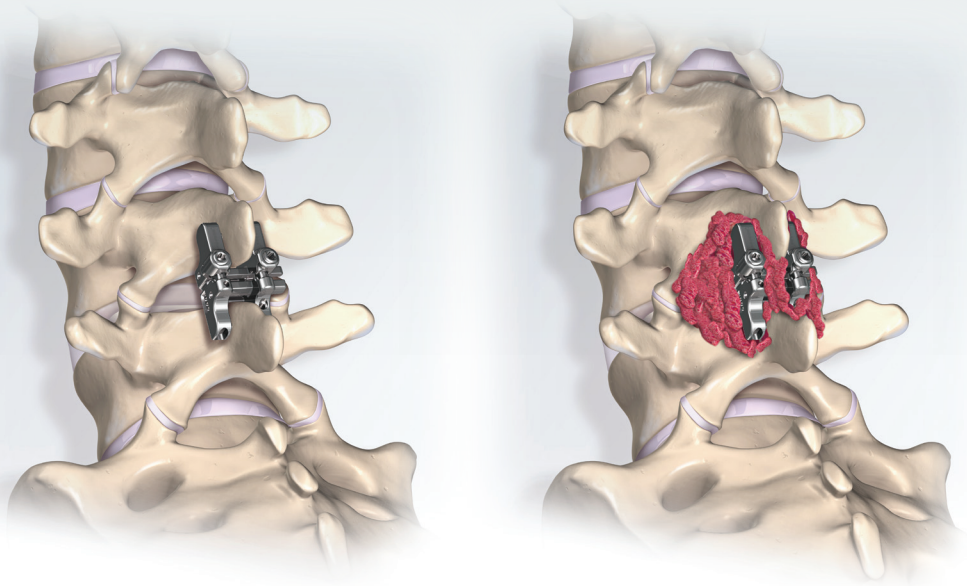

*Figure 24*  
Place bone graft in the usual manner

### STEP 32

- If fusing the facets, decorticate articular surfaces and place bone graft in the usual manner. If desired, additional posterior bone grafting material may be placed across the lamina, around the implant and/or in the posterolateral gutter (**Figure 24**).
- If not already done, bone graft material may be packed within the post of the implant.
- If the supraspinous ligament was resected, bone graft material may be packed posterior to the device between the tips of the spinous processes.
- After the construct is implanted and bone graft completed, close the surgical site using standard techniques.
- The Alpine XC device is intended for use with bone graft material, not intended for stand-alone use.



## Removing the Implant (If Necessary)



*Figure 25*  
T10 Torx

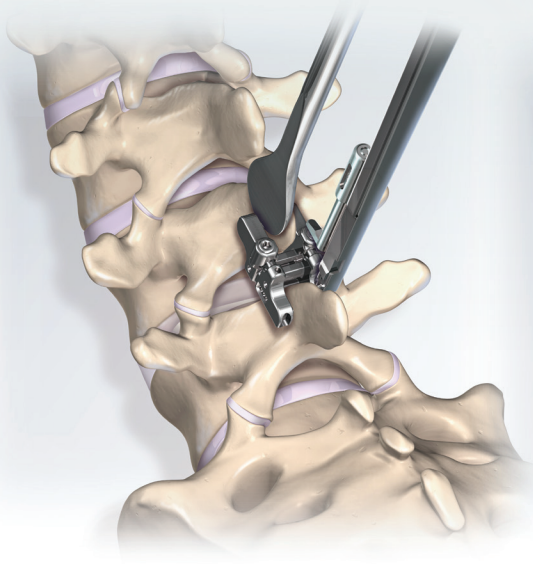

*Figure 26a*  
Preferred removal method using the lock-plate inserter and Cobb elevator

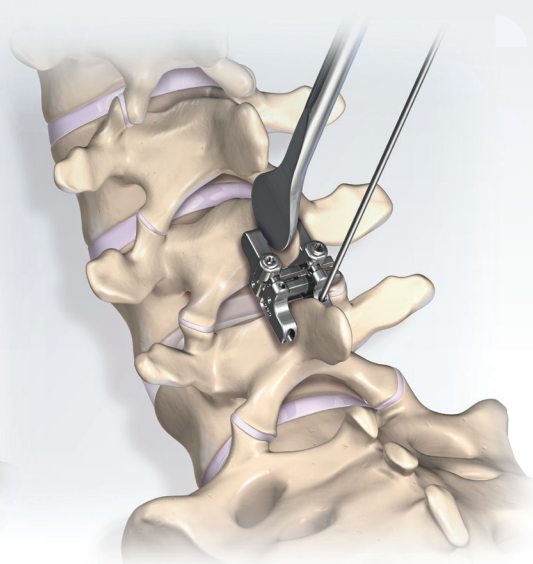

*Figure 26b*  
Alternative removal method using a 2mm diameter pin and Cobb elevator

1. Use the set screw driver (provided in the standard Alpine XC instrument set) to loosen both locking set screws. Although the system-specific set screw driver is recommended, a T10 Torx driver (**Figure 25**) may be used as a substitute.
2. Use the lock-plate inserter to disengage the ratcheting mechanism that provisionally secures the lock-plate to the post-plate. If the lock-plate inserter is not available, a 2mm diameter pin or smaller (e.g., Steinman pin, K-wire, Penfield) may be used to disengage the ratcheting mechanism.
3. While disengaging the ratcheting mechanism, use a Cobb elevator or similar instrument to separate the plates from the spinous processes (**Figure 26a, b**).

# Instruments



QUICK CONNECT HANDLE (GRAY) (2) PART NUMBER  
6200-1108



INSERTER/ADJUSTER PART NUMBER  
6330-2006



TORQUE LIMITING HANDLE 30IN-LB (BLACK) (2) PART NUMBER  
(3.4Nm) 6200-1109

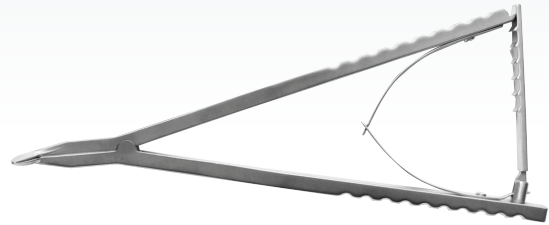

SPREADER PART NUMBER  
6200-3001



INITIAL DILATOR PART NUMBER  
Standard 6200-1400  
Skinny 6200-1401



LOCK-PLATE INSERTER PART NUMBER  
6330-2008



RASP PART NUMBER  
6mm 6200-2806  
8mm 6200-2808



SET SCREW DRIVER SHAFT (2) PART NUMBER  
6330-1104



COMPRESSOR (2) PART NUMBER  
6330-1156



INSERTER/ADJUSTER REMOVAL WRENCH PART NUMBER  
6330-2004

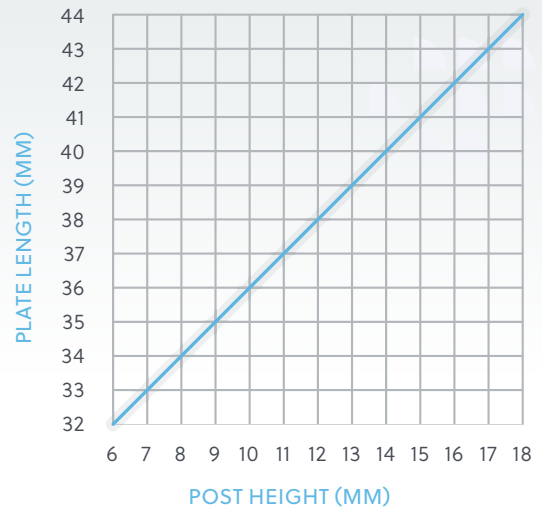
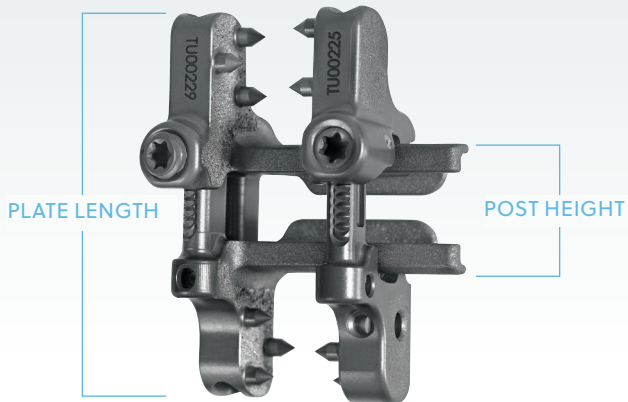

6←→18 IMPLANT CADDY (STANDARD) PART NUMBER

X = Adjustable Lock-Plate 6310-1003

Y = Adjustable Post-Plate (6←→18 Medium) 6305-1003

Z = Adjustable Post-Plate (6←→18 Wide) 6306-1003

→ = Preassembly Channel  
(slide a post-plate down this channel to attach it to a lock-plate)

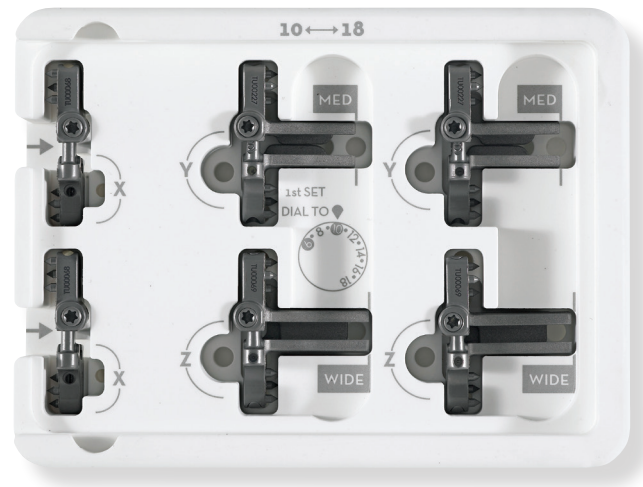

10←→18 IMPLANT CADDY (SPECIAL ORDER) PART NUMBER

X = Adjustable Lock-Plate 6310-1003

Y = Adjustable Post-Plate (10←→18 Medium) 6305-1103

Z = Adjustable Post-Plate (10←→18 Wide) 6306-1103

→ = Preassembly Channel  
(slide a post-plate down this channel to attach it to a lock-plate)

# Important Information on the Apline XC Adjustable Fusion System

## Device Description

The Alpine XC Adjustable Fusion System is a posterior attachment spinal fixation system composed of spinous process plates, dedicated surgical instruments and sterilization cases. The components are used to build a construct to provide stabilization of spinal segments in the thoracic, lumbar and sacral spine to support fusion. The Alpine XC device is part of the ZimVie Spinal Fixation System, which offers the surgeon a variety of implant components from which to assemble a suitable construct according to each individual patient's needs and requirements. It is essential to use the ZimVie implants with their specifically designed instruments.

## Indications for Use

The ZimVie Spinal Fixation System is intended to be used to help provide immobilization and stabilization of spinal segments as an adjunct to fusion of the thoracic, lumbar and/or sacral spine. The system is intended for use with autograft or allograft.

The ZimVie Spinal Fixation System is intended for posterior, non-cervical (T1–S2/ilium) pedicle and non-pedicle spinal fixation, to provide immobilization and stabilization of spinal segments in skeletally mature patients as an adjunct to fusion in the treatment of the following instabilities or deformities: degenerative disc disease (DDD, defined as back pain of discogenic origin with degeneration of the disc confirmed by history and radiographic studies); spondylolisthesis; trauma (i.e., fracture or dislocation); spinal stenosis; deformities or curvatures (i.e., scoliosis, kyphosis and/or lordosis); tumor; pseudarthrosis; and failed previous fusion.

The Alpine XC Adjustable Fusion System device is a posterior, non-pedicle supplemental fixation device, intended for use at a single level in the non-cervical spine (T1–S1). It is intended for plate fixation/attachment to spinous processes for the purpose of achieving supplemental fusion in the following conditions: DDD; spondylolisthesis; trauma (i.e., fracture or dislocation); and/or tumor. The Alpine XC Adjustable Fusion System device is intended for use with bone graft material, not intended for stand-alone use.

## Contraindications

Contraindications may be relative or absolute. The choice of a particular device must be carefully weighed against the patient's overall evaluation. Circumstances listed below may reduce the chance of a successful outcome. Contraindications include, but are not limited to:

- An allergy to titanium or cobalt chrome alloys, or foreign body sensitivity. Where material sensitivity is suspected, appropriate tests must be made prior to implantation.
- Known or suspected infection/immune system incompetence. Acute or chronic infectious diseases of any etiology or localization.
- Any abnormality present which affects the normal process of bone remodeling including, but not limited to, severe osteoporosis involving the spine, bone absorption, osteopenia, active infection at the site or certain metabolic disorders affecting osteogenesis.
- Morbid Obesity. An overweight or obese patient can produce loads on the spinal system, which can lead to failure of the fixation of the device or failure of the device itself.
- Any neuromuscular deficit which places an unusually heavy load on the device during the healing period.
- Open Wounds.
- Pregnancy.
- Any other medical or surgical condition which would preclude the potential benefit of spinal surgery, such as the presence of congenital abnormalities, elevation of sedimentation rate unexplained by other diseases, elevation of the white blood cell (WBC) count or a marked left shift in the WBC differential count.
- Any case requiring the mixing of components from other manufacturers' systems.
- Any case requiring the mixture of stainless steel with titanium, or stainless steel with cobalt chrome implant components.
- Fever or leukocytosis.
- Signs of local infection or inflammation.
- Previous history of infection.
- Alcoholism or heavy smoking.
- Senility, mental illness or substance abuse, of a severity that the patient may ignore certain necessary limitations and precautions in the use of the implant, leading to failure or other complications.
- Any patient unwilling to follow postoperative instructions.
- Inadequate tissue coverage over the operative site.
- The Alpine XC device is also contraindicated in cases where the posterior arch is missing or incomplete (e.g., laminectomy, pars defect, severe osteoporosis).

## Possible Complications

Possible complications specific to the device may include:

- Early or late implant bending, breakage, failure, loosening or movement/migration.
- Bone and/or spinous process fracture.
- Allergic reaction to implant material.

Other general complications associated with any spinal surgical procedure may include: non-union or delayed union, pseudarthrosis; pain; second surgery; bleeding; infection, early and late; tissue or nerve damage, including dural tears or other neurological problems; incisional complications; scar formation; damage to blood vessels and cardiovascular system compromise; changes in mental status; damage to internal organs and connective tissue; complications due to the use of bone grafting, including graft donor site complications; respiratory problems; reactions to anesthesia and/or death.

## Warnings

A successful result is not always achieved in every surgical case. This fact is especially true in spinal surgery, where many extenuating circumstances may compromise the results.

## Precautions

- The Alpine XC Adjustable Fusion System implants are for single use only. Never reuse any implant even if it appears unmarked or undamaged. Reuse of the implant components may result in reduced mechanical performance, malfunction or failure of the device. Any implant implanted and then removed must be discarded. Use only new implants for each case.
- The implantation of spinal fixation systems must only be performed by experienced spinal surgeons with specific training in the use of this system due to the technically demanding procedure presenting a risk of serious injury to the patient.
- Based on the fatigue testing results, the physician/surgeon must consider the levels of implantation, patient weight, patient activity level, other patient conditions, etc. which may impact on the performance of the system.
- **Preoperatively:** The surgeon must be fully conversant with all aspects of the surgical technique and know the indications and contraindications of this type of implant. The surgeon must have acquainted himself before the operation with the specific technique for insertion of the product, which is available from the manufacturer. As part of the preoperative examination, the surgeon must check that no biological, biomechanical or other factors will affect the correct conduct of the operation and the postoperative period. An appropriate range of implant sizes must be available at the time of the operation.

- **Intraoperatively:** The correct selection of the type and size of implant appropriate to the patient and the positioning of the implant are extremely important.
- **Postoperatively:** Patients must be informed of the precautions to be taken in their everyday life to guarantee a maximum implant service life. It is recommended that regular postoperative follow-up is undertaken to detect early signs of failure of the implants and to consider the action to be taken. Deterioration of the device after bone consolidation cannot be considered to constitute a dysfunction or deterioration in the characteristics of the implants. The implant can be removed after bony healing.
- The Alpine XC device has not been evaluated for safety and compatibility in the magnetic resonance (MR) environment. The Alpine XC device has not been tested for heating or migration in the MR environment.
- Federal law (USA) restricts this device to sale by or on the order of a physician.

## Sterilization

The Alpine XC implants and instruments are supplied non-sterile. Implants and instruments must be sterilized prior to use. The recommended sterilization process is steam autoclave sterilization, using the parameters listed in the table below. Use of an FDA-cleared wrap is recommended to maintain sterility prior to use.

| Method | Cycle      | Temperature     | Exposure Time | Minimum Dry Time |
|--------|------------|-----------------|---------------|------------------|
| Steam  | Pre-Vacuum | 132° C (270° F) | 4 minutes     | 30 minutes       |
| Steam  | Gravity    | 132° C (270° F) | 15 minutes    | 50 minutes       |

Where Immediate Use Steam Sterilization (IUSS) is needed, each of the Alpine XC Manual Surgical Instruments may be sterilized individually using the following sterilization parameters.

| Alpine XC System Single Instrument IUSS Parameters |         |                 |               |
|--|---------|-----------------|---------------|
| Method   | Cycle   | Temperature     | Exposure Time |
| Steam  | Gravity | 132° C (270° F) | 15 minutes    |

The recommended sterilization cycles have been validated to assure a Sterility Assurance Level (SAL) of at least 10<sup>-6</sup>.

For more information, visit [ZimVie.com](https://www.zimvie.com)



**Manufactured by:**  
Zimmer Biomet Spine, Inc.  
10225 Westmoor Dr.  
Westminster, CO 80021 USA  
[ZimVie.com](https://www.zimvie.com)



Biomet 3i Dental Iberica, S.L.U  
WTC Almeda Park, Edif. 4, Planta 2  
Tirso de Molina, 40  
08940 Cornellà de Llobregat  
Barcelona, Spain  
+900 800 303



**Disclaimer:** This document is intended exclusively for physicians and is not intended for laypersons. Distribution to any other recipient is prohibited. Information on the products and procedures contained in this document is of a general nature and does not represent and does not constitute medical advice or recommendations. Because this information does not purport to constitute any diagnostic or therapeutic statement with regard to any individual medical case, each patient must be examined and advised individually, and this document does not replace the need for such examination and/or advice in whole or in part.

**Caution:** Federal (USA) law restricts this device to sale by or on the order of a physician. Rx only. Please refer to the package inserts for important product information, including, but not limited to, indications, contraindications, warnings, precautions, adverse effects, and patient counseling information.

Unless otherwise indicated, as referenced herein, all trademarks and intellectual property rights are the property of ZimVie Inc. or an affiliate; and all products are manufactured by one or more of the spinal subsidiaries of ZimVie Inc. (Zimmer Biomet Spine, Inc., Zimmer Spine, LDR Medical, etc.) and marketed and distributed by Zimmer Biomet Spine and its authorized marketing partners. Please refer to the Instructions for Use and the package label for the products to be used with this Surgical Technique. Product clearance and availability may be limited to certain countries/regions. This material is intended for clinicians only and does not comprise medical advice or recommendations. Distribution to any other recipient is prohibited. This material may not be copied or reprinted without the express written consent of ZimVie. 0279.2-US-EN-2023.12 ©2023 ZimVie Inc. All rights reserved.

